

## Respiratory Gas Analysis

Grant McFadyen

Correspondence Email: Bruce.McCormick@rdefn.nhs.uk

### OXYGEN CONCENTRATION ANALYSERS

It is important to measure the oxygen concentration in the gas mixture delivered to a patient during anaesthesia. There are three main techniques available for measurement of the inspired oxygen concentration ( $\text{FiO}_2$ ): galvanic, polarographic and paramagnetic techniques. The paramagnetic method is currently the most widely used in modern anaesthetic machines, however galvanic fuel cells and the polarographic electrode are found in older machines. These analysers measure the oxygen partial pressure in a gas sample but they display a percentage. Regular calibration of oxygen analysers is vital.

### Paramagnetic oxygen analysers

Oxygen possesses the property of *paramagnetism*, which means that it is weakly attracted into a magnetic field. This is because it has two electrons in unpaired orbits. Most of the gases used in anaesthesia are repelled by a magnetic field (diamagnetism).

The sample gas, taken from the breathing circuit, is delivered to the analyser via a sampling tube, which should be placed as close as possible to the patient's airway. Older paramagnetic analysers used a principle described by Figure 1.

Newer analysers have two chambers separated by a sensitive pressure transducer. The sample gas is delivered to one chamber and room air is delivered to the reference chamber. An electromagnet is rapidly switched on and off creating a changing magnetic field to which the sample gas is subjected. The magnetic field causes the oxygen molecules to be attracted and agitated. This results in changes in pressure on either side of the pressure transducer. The pressure difference across the transducer is proportional to the oxygen partial pressure difference between the sample gas and the reference gas (room air, containing 21% oxygen).

Paramagnetic oxygen analysers are very accurate and highly sensitive. The analysers should function continuously without any service breaks. They have a rapid response allowing measurement of inspiratory and expiratory oxygen on a breath-to-breath basis. They are affected by water vapour and have a water trap incorporated into their design.

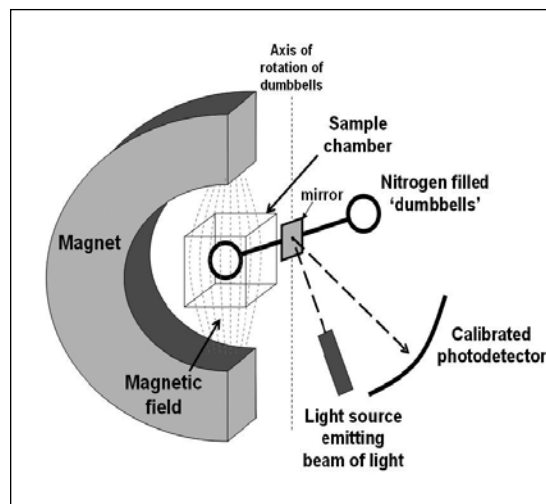

**Figure 1.** A paramagnetic analyser. The sample gas fills the sample chamber. Oxygen in the sample is attracted into the magnetic field and tends to displace the nitrogen filled dumbbell, which has no paramagnetic properties. The greater the concentration of oxygen present, the greater the displacement of the dumbbell. The degree of rotation of the pair of dumbbells is recorded by the amount a light beam is deflected, by a mirror mounted on the dumbbell axis

### The galvanic oxygen analyser (Fuel cell)

The galvanic analyser is placed on the inspiratory limb of the breathing system (Figure 2). Oxygen molecules diffuse across a membrane and an electrolyte solution, to a gold (or silver) cathode, which is connected through the electrolyte solution to a lead anode. An electrical current is generated which is proportional to the partial pressure of oxygen in the inspired gas. The equation describing the reaction is:



The galvanic analyser has a response time of approximately twenty seconds and is accurate to within 3%. Calibration is achieved using 100% oxygen and room air (21% oxygen). Water vapour does not affect its performance. It has the advantage that it is a battery and therefore self-powering, however it is depleted by continuous exposure to oxygen due to exhaustion of the cell, so limiting its life span to about one year.

### Summary

Monitoring of respiratory gases is considered by most to be highly important for the conduct of safe anaesthesia. Monitoring of inspired oxygen levels ensures against delivery of hypoxic gas mixtures to the patient and is useful for titration of oxygen flow where oxygen supplies are limited. Capnography tells an anaesthetist a great deal about the clinical status of the patient, both in terms of their respiratory and cardiovascular systems. It also lowers the threshold for suspicion for rare but potential fatal pathologies such as malignant hyperpyrexia. It many settings agent monitoring is not available, but its value in detecting and avoiding harmful overdose of anaesthetic agents or awareness due to insufficient levels, mean that, ideally, it should be incorporated into all anaesthetist's practice.

**Grant McFadyen**  
Consultant Anaesthetist  
Morrison Hospital  
Swansea SA6 6NL  
UK

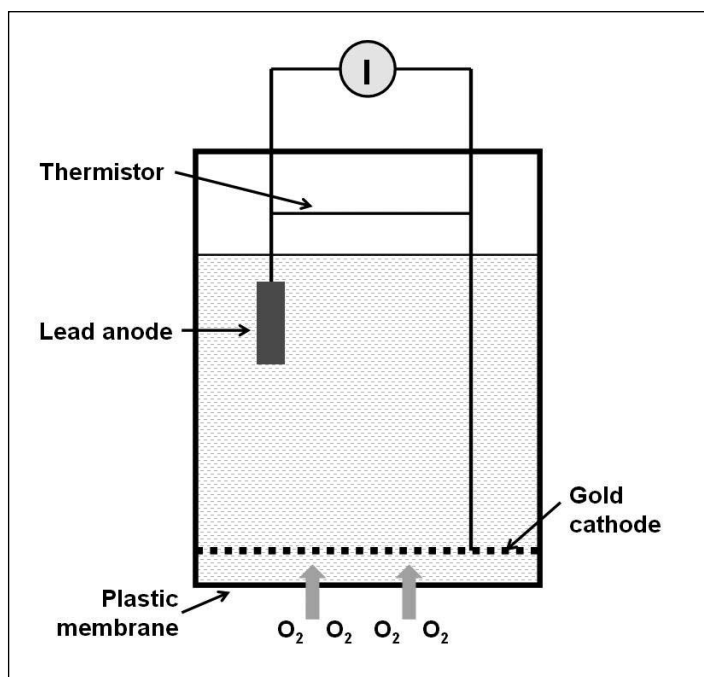

**Figure 2.** The galvanic oxygen analyser (Fuel cell)

### The polarographic oxygen analyser (Clark electrode)

The polarographic analyser has similar principles to the galvanic analyser (Figure 3). Oxygen molecules diffuse across a teflon membrane. Current flows between a silver cathode and a platinum anode, which is proportional to the partial pressure of oxygen in the inspiratory gas. It is battery powered, but its life expectancy is limited to about three years because of deterioration of the teflon membrane.

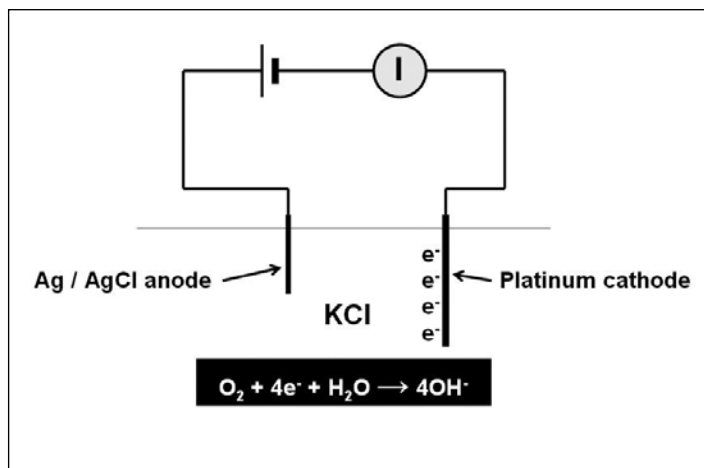

**Figure 3.** The polarographic oxygen analyser (Clark electrode)

## CAPNOGRAPHY

Capnometry is the measurement of carbon dioxide (CO<sub>2</sub>) and capnography is the display of the change in CO<sub>2</sub> level with the respiratory cycle. The capnograph displays a waveform of CO<sub>2</sub> - measured in kilopascals (kPa), millimetres of mercury (mmHg) or percentage - and also displays the numerical value of the CO<sub>2</sub> at the end of exhalation, the end-tidal CO<sub>2</sub>, which is the closest value to partial pressure of CO<sub>2</sub> in the alveolus or arterial blood.

It is useful to measure CO<sub>2</sub> to assess the adequacy of ventilation, to confirm tracheal intubation, to detect oesophageal intubation, to indicate disconnection of the breathing system or ventilator, and to diagnose circulatory problems and malignant hyperthermia.

### Applications of capnography

Provided the patient has a stable cardiac status, stable body temperature, absence of lung disease and a normal capnograph trace, end-tidal carbon dioxide (ETCO<sub>2</sub>) can be estimated to be about 0.5-1.0kPa below the partial pressure of CO<sub>2</sub> in arterial blood (PaCO<sub>2</sub>). A normal PaCO<sub>2</sub> is about 5.3kPa (40mmHg). Note that the conversion factor between kPa and mmHg is 7.6.

Under the conditions described above, ETCO<sub>2</sub> can be used to assess the adequacy of ventilation - i.e. hypo-, normo-, or hyperventilation. ETCO<sub>2</sub> is not as reliable in patients who have respiratory failure. Any increased ventilation/perfusion (V/Q) mismatch is associated with a widened partial pressure (a-ET) gradient, and leads to ETCO<sub>2</sub> values that do not correlate with the true PaCO<sub>2</sub>.

The capnograph is the gold standard for detecting oesophageal intubation. No or very little CO<sub>2</sub> is detected if the oesophagus has been intubated.

The capnograph is also useful in the following circumstances:

- As a disconnection alarm for a ventilator or a breathing system. There is sudden absence of the capnograph trace.
- It may detect air embolism as a sudden decrease in ETCO<sub>2</sub>, assuming that the arterial blood pressure remains stable.
- To recognise sudden circulatory collapse as a sudden decrease in ETCO<sub>2</sub>.
- To diagnose malignant hyperthermia as a gradual increase in ETCO<sub>2</sub>.

### Techniques of measurement

Most analysers in theatre work using two principles:

#### Infrared absorption spectroscopy

This is the most commonly used technique in anaesthesia. Gases of molecules that contain at least two dissimilar atoms absorb infrared radiation. Using this property, CO<sub>2</sub> concentration can be measured continuously throughout the respiratory cycle to give a capnograph trace. CO<sub>2</sub> absorbs infrared radiation particularly effectively at a wavelength of 4.3micrometers. A photodetector measures radiation reaching it from a light source at this wavelength. According to the Beer-Lambert Law, the amount of infrared radiation absorbed in the CO<sub>2</sub> sample chamber is proportional to the number of CO<sub>2</sub> molecules (partial pressure of CO<sub>2</sub>) present in the chamber, and so the CO<sub>2</sub> concentration can be calculated.

#### Photo-acoustic spectroscopy

The sample gas is irradiated with pulsatile infrared radiation, of a suitable wavelength. Periodic expansion and contraction of the gas produces a pressure fluctuation of audible frequency that can be detected by a microphone. The advantages of photo-acoustic spectrometry over conventional infrared absorption spectrometry are:

- The photo-acoustic technique is extremely stable and its calibration remains constant over much longer periods of time.
- The very fast rise and fall times give a much truer representation of any change in CO<sub>2</sub> concentration.

Other techniques for measuring CO<sub>2</sub> include Raman scattering and mass spectrometry.

#### Raman scattering

When light passes through a gas sample it can undergo two types of reflective process:

1. *Rayleigh* scattering – where there is no change in the energy or frequency of the light,
2. *Raman* scattering – where the incident light loses energy to the molecules of the gas and is reflected at lower frequency (less than 1 millionth of the time).

The magnitude of the light frequency shift is specific to the gas and analysis of the reflected light allows identification of the gas. The light used is *intense, coherent and monochromatic* (i.e. from a laser). The machines are rapid, with breath to breath analysis, but tend to be bulky and heavy. They are more versatile than infra-red analysis and more reliable than mass spectrometry.

#### Site of sampling within the breathing system

Gas from the breathing system can be sampled either by a sidestream or a mainstream analyser.

#### Sidestream sampling

Gas is drawn from the breathing system by a 1.2mm internal diameter tube. The tube is connected to a lightweight adapter near the patient's end of the breathing system. It delivers the gas to the sample chamber. It is made of Teflon so it is impermeable to CO<sub>2</sub> and does not react with anaesthetic agents. Only the precise tubing recommended by the manufacturer should be used and only of the recommended length. Typical infrared instruments sample at a flow rate between 50 and 150ml.min<sup>-1</sup>. When low fresh gas flows are used the sampled gas may be returned to the breathing circuit. It is important that the tip of the sampling tube should always be as near as possible to the patient's trachea, but the sampled gas mixture must not be contaminated by inspired gas during the expiratory phase.

#### Mainstream sampling

The sample chamber is positioned within the gas stream near the patient's end of the breathing system. Although heavier and more cumbersome, it does have advantages over sidestream sampling:

- The delay between the rise and fall times of gas composition changes and display on the capnograph is less, as gas does not need to be transported to the monitor.
- No gas is drawn from the breathing system.
- The mixing of gas that occurs along the sample tube with sidestream sampling is avoided.
- There are fewer problems with water vapour condensation.

#### The capnograph trace (Figure 4)

The first phase occurs during inspiration. The second phase is the onset

of expiration, which results in a rapid increase in the CO<sub>2</sub> reading. The third phase, the expiratory plateau, occurs as the CO<sub>2</sub> is exhaled from all of the alveoli. The highest point of the plateau is taken to represent the end-tidal CO<sub>2</sub> (ETCO<sub>2</sub>). This marks the end of expiration. Phase four is the onset of inspiration.

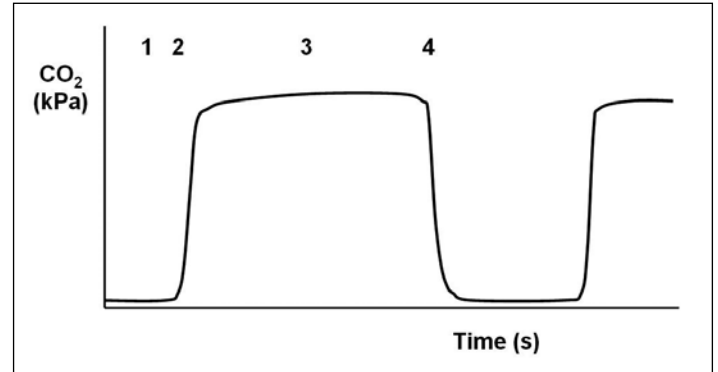

**Figure 4.** A typical capnography trace; 1 inspiratory baseline; 2 expiratory upstroke; 3 expiratory plateau; 4 inspiratory downstroke

#### Abnormal capnography traces

##### Rebreathing (Figure 5)

A waveform that does not return to the baseline during inspiration indicates rebreathing of exhaled CO<sub>2</sub>-containing gas. Possible causes are:

- The fresh gas flow is too low in non-rebreathing system (e.g. Mapelson type A, D or E).
- The soda lime in a circle system is depleted.

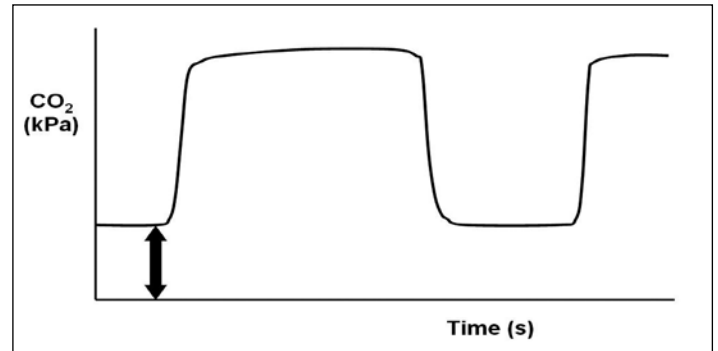

**Figure 5.** Rebreathing is indicated by failure of the trace to return to the baseline during inspiration (arrow)

##### Sloping plateau (Figure 6)

This appearance is seen in patients with obstructive airways disease (asthma and chronic obstructive pulmonary disease). In patients with obstructive airways disease, the lungs are perfused with blood as normal, but the alveoli are unevenly ventilated. CO<sub>2</sub> is transferred from the alveoli to the larger airways during expiration, but this takes longer in lung units that have narrower bronchi. These slower emptying lung units have a higher CO<sub>2</sub> concentration and so the CO<sub>2</sub> concentration in mixed expired gas gradually rises throughout expiration, as these slow emptying units contribute a greater proportion of the expired gas mixture.

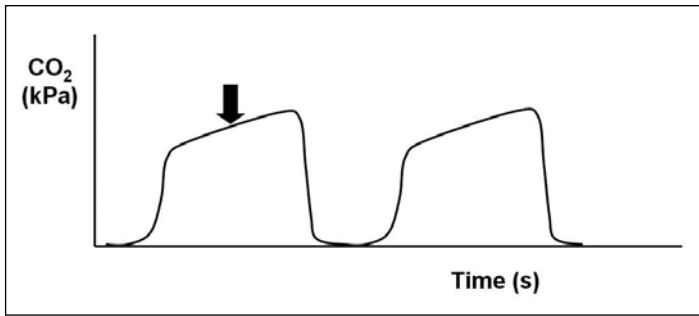

**Figure 6.** The sloping plateau (arrowed) is typical of lower airways obstruction (asthma and COPD)

#### Cardiac oscillations

Cardiac impulses are transmitted through the mediastinum to the large airways and are detected by the capnograph. These oscillations are most obvious in apnoeic patients, since the volume of gas that

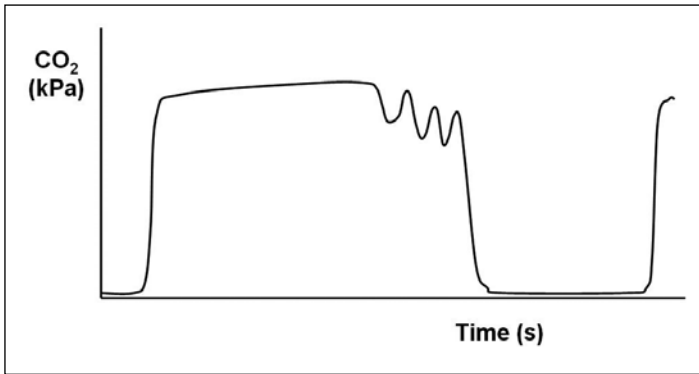
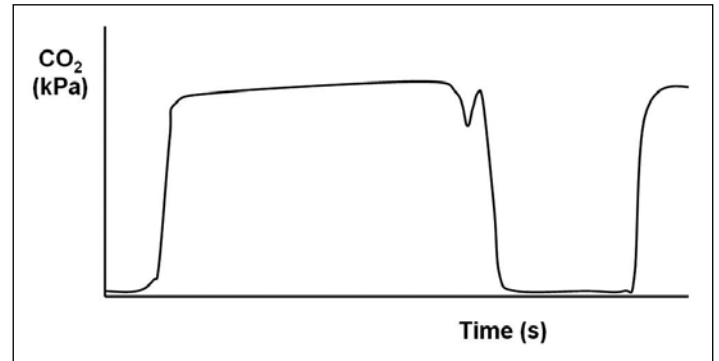

**Figure 7.** Cardiac oscillations.

they cause to move in the airways is a greater proportion of the overall lung volume when the patient is at functional residual capacity.

#### The 'curare cleft' (Figure 8)

This appearance indicates reversal of neuromuscular blockade in a ventilated patient. When a paralysed patient starts taking small breaths as the neuromuscular blocking agent reverses, clefts are seen on the capnograph trace.



**Figure 8.** Breathing against the ventilator.

#### FURTHER READING

- Williamson JA, Webb RK, Cockings J, Morgan C. The Australia incident monitoring study. The capnograph: applications and limitations - an analysis of 2000 incident reports. *Anaesthesia and Analgesia* 1993; **21**: 551-7
- Schmitz BD, Shapiro BA. Capnography. *Respiratory Care Clinics of North America*. 1995; **1**: 107-17
- Al-Shaikh B, Essentials of Anaesthetic Equipment. Churchill Livingstone 1995.